

# 3 Port Solenoid Valve

## Series S070

Rubber Seal

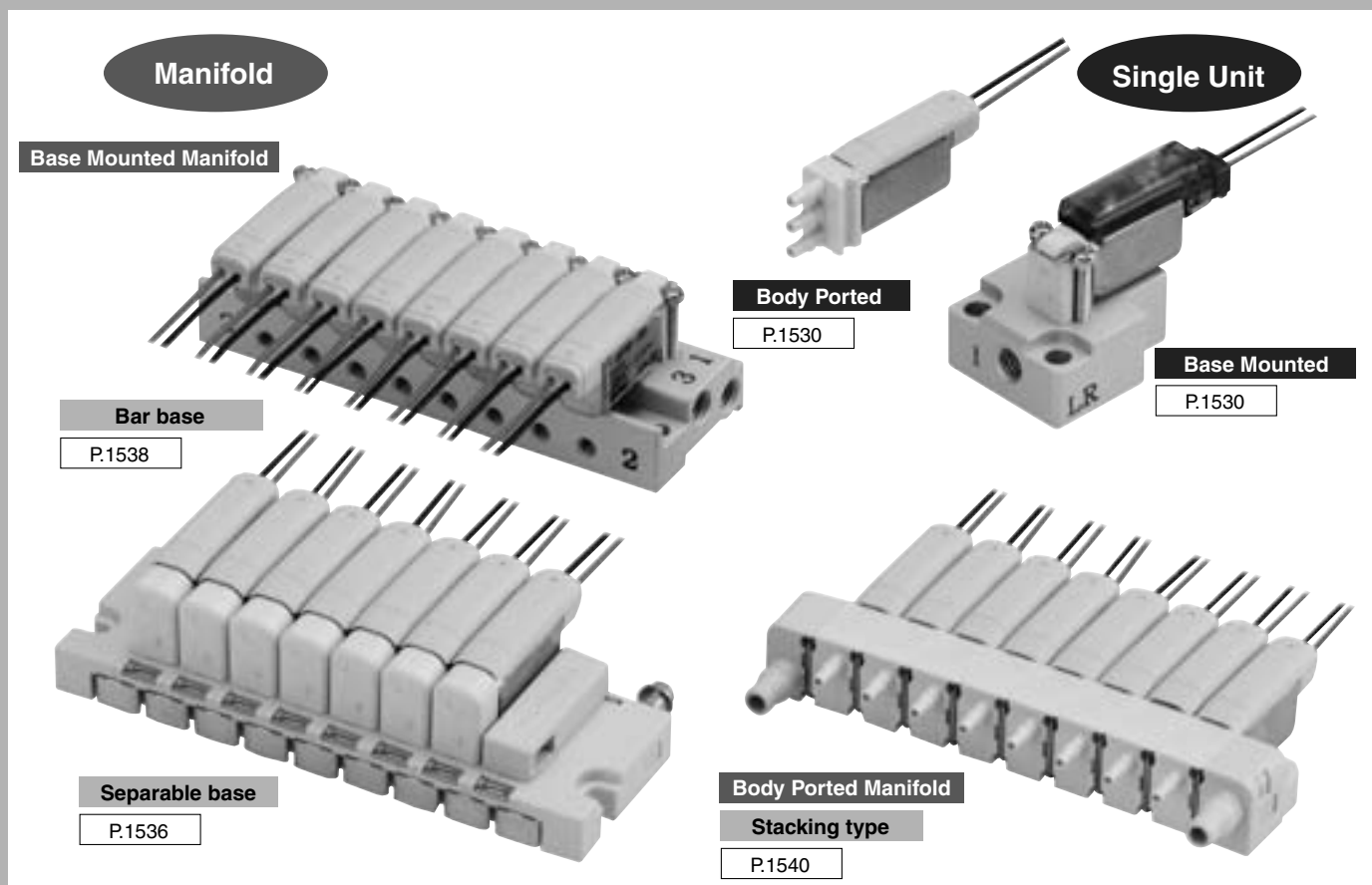

VV061

V100

S070

VQD

VKF

VK

VT

VS

- Valve width **7** mm
- Mass **5** g (single unit valve)

- Power consumption **0.35** W (Standard),  
**0.1** W (With power saving circuit)
- Operation noise **38** dB (A) or less
- Sonic conductance: C **0.083** [dm<sup>3</sup>/(s·bar)]
- Stacking type manifold



Separable base

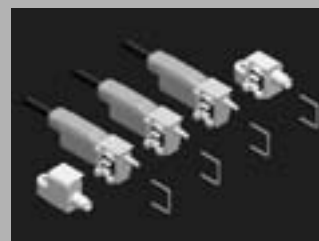

Stacking type

# 3 Port Solenoid Valve Compact Direct Operated Series S070



## How to Order Valve

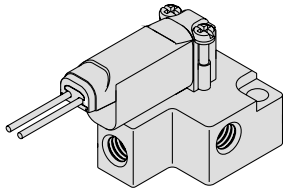

Base mounted

S070 B - 5 B G -

Body ported

S070 C - 5 B G - 32

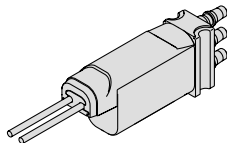

### Body type

Symbol	Body type
B	Base mounted with screws

### Port size

Symbol	Sub-plate
Nil	Without sub-plate
M3	With sub-plate
M5	

### Body type

Symbol	Body type
C	Body ported

### Port size

Symbol	Connection	Applicable tubing
32	Barb fitting	ø3.18/ø2

### Coil voltage

5	24 VDC
6	12 VDC
V	6 VDC
S	5 VDC
R	3 VDC

### Electrical entry

G – Grommet

C – Plug lead with light/  
surge voltage  
suppressor

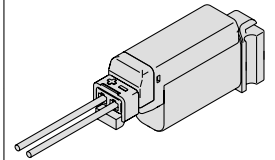
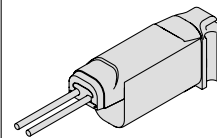

CO – Plug lead without connector  
and with light/surge voltage  
suppressor

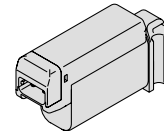

### Power consumption – Pressure specification – Flow rate

Symbol	Power consumption (W)	Maximum operating pressure (MPa)	Cv factor
A	0.35	0.1	0.016
B		0.3	0.011
C		0.3	0.016
D	0.5	0.5	0.011
E <small>Note</small>	0.1 (With power saving circuit)	0.1	0.011
F <small>Note</small>		0.3	0.006



Note) An option only applicable to 24 VDC plug lead type.



### Made to Order

(Refer to page 1542 for details.)

Symbol	Specifications/Content
X26	Grommet type, Special lead wire length
X50	Universal type
X62	Normally open type

# 3 Port Solenoid Valve Compact Direct Operated **Series S070**

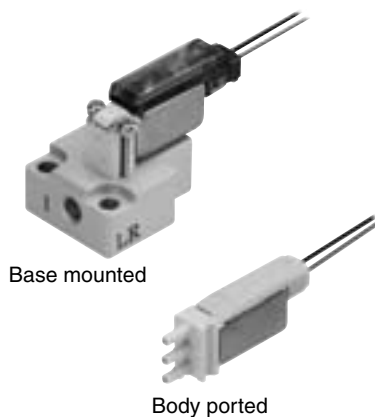

JIS Symbol

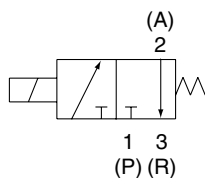

## Specifications

Valve construction	Poppet
Fluid	Air/Inert gas/Low vacuum ( $1.33 \times 10^2$ Pa)
Maximum operating pressure	0.3 MPa (0.35 W, 0.1 W), 0.5 MPa (0.5 W)
Proof pressure	1 MPa
Ambient and fluid temperature <sup>Note 1)</sup>	-10 to 50°C
Lubrication	Not required
Impact/Vibration resistance <sup>Note 2)</sup>	30/150 m/s <sup>2</sup>
Enclosure	IP40
Mass	5 g (Single unit valve)
Mounting orientation	Free



Note 1) Use dry air and prevent condensation at low temperatures.

Note 2) Vibration resistance: No malfunction resulted in 45 to 2000 Hz, a one-sweep test performed in the axial and right angle directions of the main valve and armature for both energized and de-energized states.

Impact resistance: No malfunction resulted in an impact test using a drop impact tester. The test was performed one time each in the axial and right angle directions of the main valve and armature, for both energized and de-energized states.

Note 3) With the low vacuum specification, the operating pressure range is  $1.33 \times 10^2$  Pa to the maximum operating pressure.

## Solenoid Specifications

Power consumption <sup>Note 1)</sup>	0.35 W (Standard), 0.5 W (High voltage), 0.1 W (Holding)
Rated coil voltage	3, 5, 6, 12, 24 VDC
Allowable voltage fluctuation	±10% of the rated voltage
Coil insulation type	Equivalent to class B



Note 1) With a light/surge voltage suppressor and power saving circuit, the light consumes a power equivalent to 2 mA.

## Flow Specifications/Response Time

Power consumption	Maximum operating pressure	Flow characteristics			Response time ms <sup>Note 2)</sup>	
		C[dm <sup>3</sup> /(s.bar)]	b	Cv	ON	OFF
0.5 W DC	0.5 MPa	0.042	0.27	0.011	3 or less	3 or less
	0.3 MPa	0.060	0.28	0.016	5 or less	3 or less
0.35 W DC	0.3 MPa	0.042	0.27	0.011	3 or less	3 or less
	0.1 MPa	0.060	0.28	0.016	5 or less	3 or less
0.1 W DC (at holding) with power saving circuit <sup>Note 1)</sup>	0.3 MPa	0.021	0.27	0.006	3 or less	6 or less
	0.1 MPa	0.042	0.28	0.011	5 or less	6 or less



Note 1) 0.35 W DC at inrush (100 ms) and 0.1 W DC at holding.

Note 2) The response time is the value at the rated voltage and maximum operating pressure.

VV061

V100

S070

VQD

VKF

VK

VT

VS

# Series S070

## Construction

### Component Parts

Number	Description	Material
1	Solenoid coil	—
2	Body	Resin
3	Core	Stainless steel
4	Armature assembly	Stainless steel, resin
5	Return spring	Stainless steel
6	Poppet	FKM
7	Interface gasket	HNBR
8	Mounting screw	Carbon steel
9	Sub-plate	Aluminum

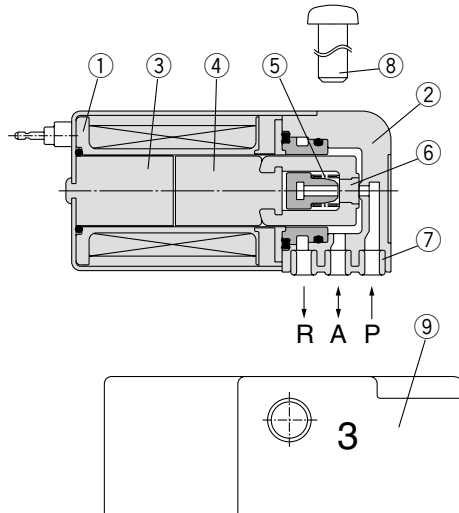

\* The above figure is an example of S070B-□□G base piping type (mounted with screws).

## Replacement Parts

### Plug connector assembly (for plug lead)

S070-14A-□

• Lead wire length

Nil	150 mm
3	300 mm
6	600 mm
10	1000 mm

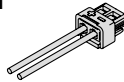

### ⑨ Sub-plate

S070-S-M3

• Port size

M3	M3 female thread
M5	M5 female thread

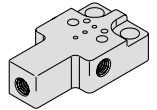

### ⑦ Interface gasket

Valve model	Gasket no.
S070A	S070A-80A-1
S070B	S070B-80A-1
S070M	S070M-80A-1



Note) Order is accepted in 10 units.

### ⑧ Mounting screw

Valve model	Mounting screw no.
S070B	AXT632-106A-1
S070C	AXT632-106A-2



Note) The above part number consists of 10 units. Each unit has two screws. Order is accepted in 10 units.

### Bracket (S070B)

Valve model	Bracket no.	Note
S070B, SS073B	S070B-80A-2	For sub-plates and manifolds (more than 3 stations)
SS073B	S070B-80A-3	For manifolds (more than 2 stations)



Note) Order is accepted in 10 units.

\* This is used when mounting a valve on the sub-plate and manifold.

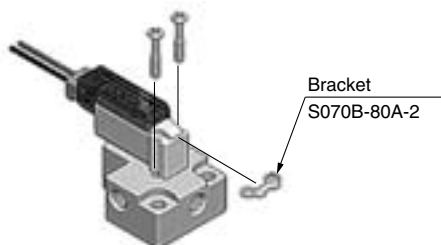

Single unit (base mounted)

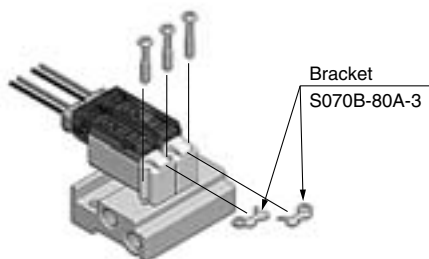

Manifold with 2 stations

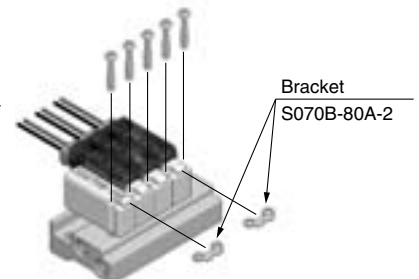

Manifold with more than 3 stations

**Dimensions**

Base mounted with screws

**S070B-□□G-M3**  
Grommet type

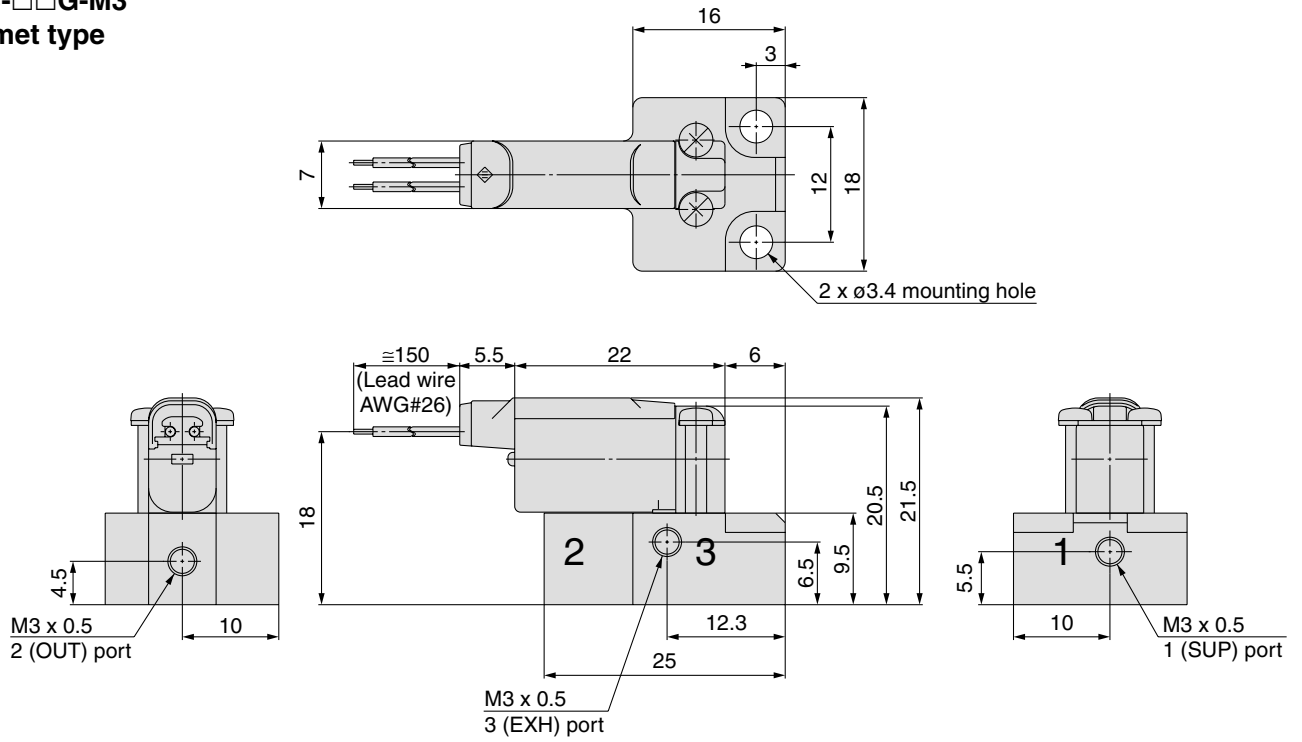

VV061
V100
<b>S070</b>
VQD
VKF
VK
VT
VS

**S070B-□□C-M3**  
Plug lead type

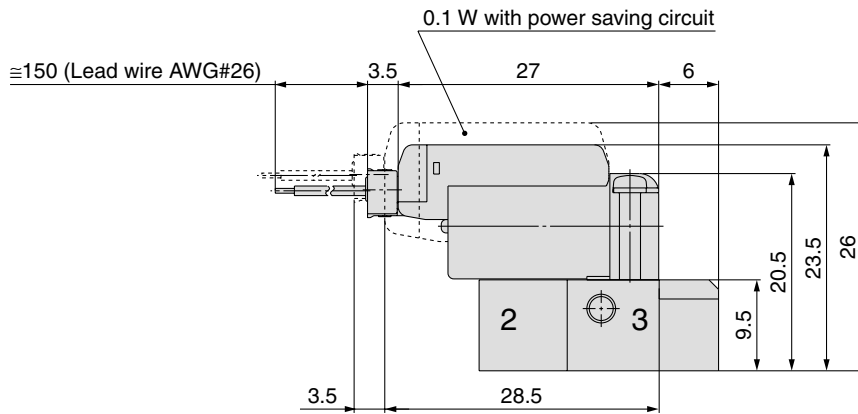

# Series S070

## Dimensions

Base mounted with screws

S070B-□□G-M5  
Grommet type

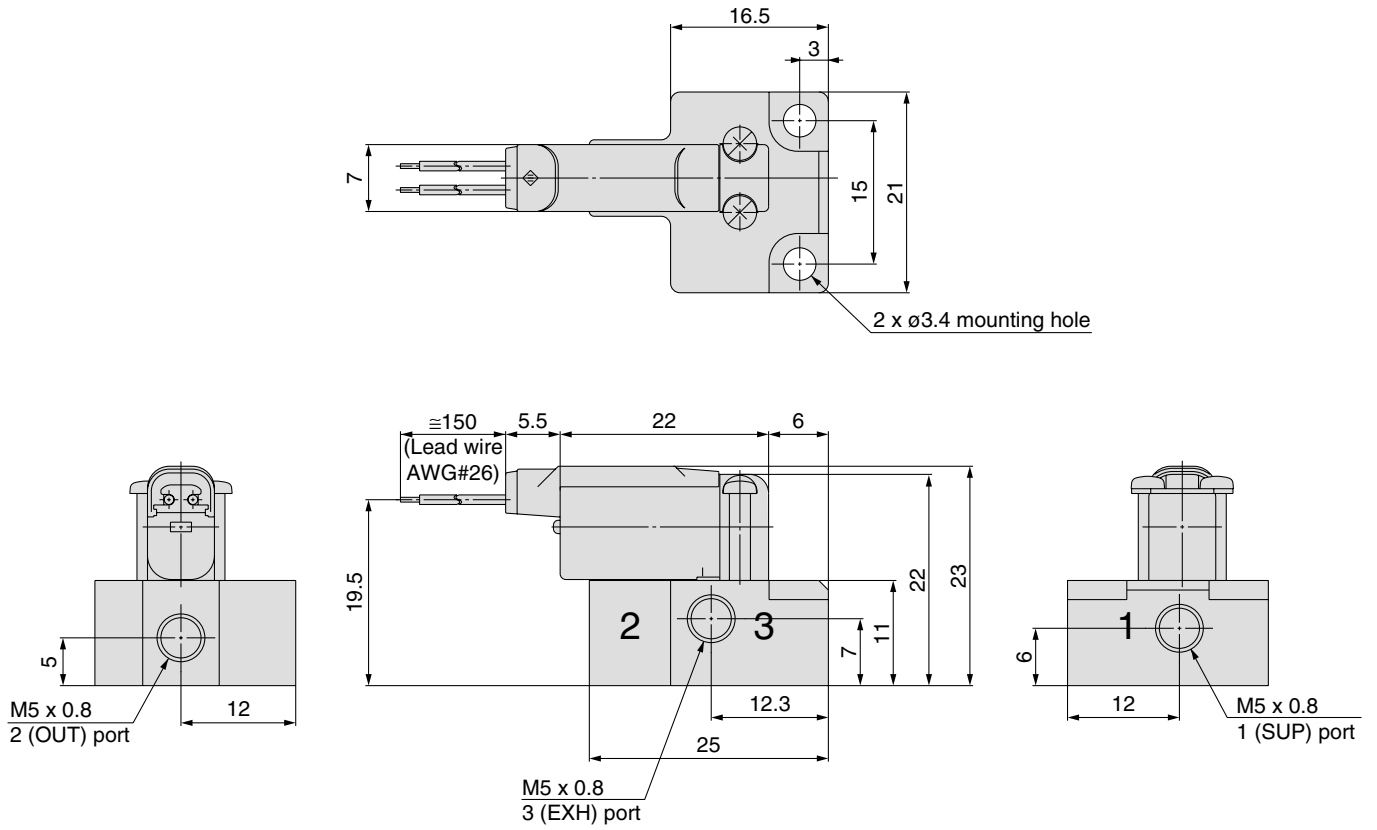

S070B-□□C-M5  
Plug lead type

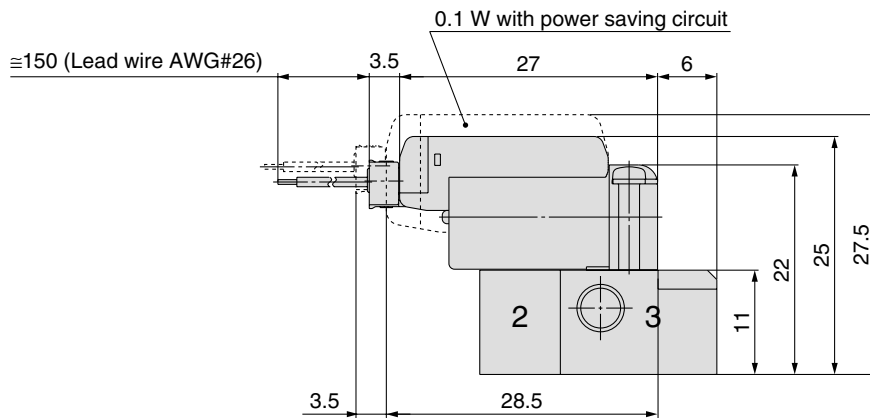

# 3 Port Solenoid Valve Compact Direct Operated **Series S070**

## Dimensions

### Body ported

S070C-□□G-32  
Grommet type

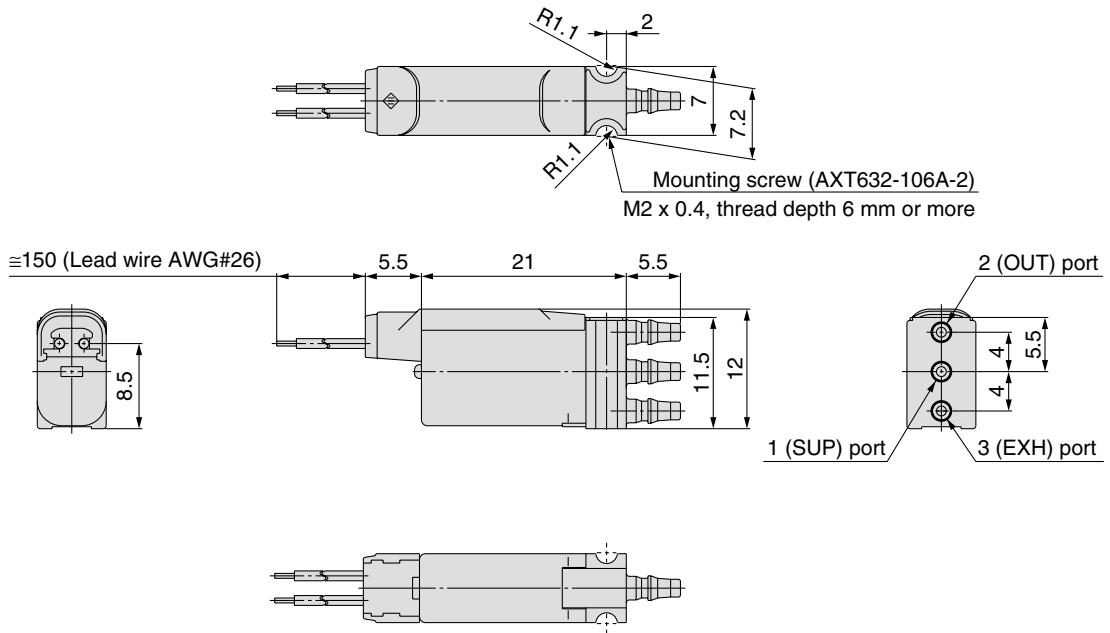

VV061

V100

**S070**

VQD

VKF

VK

VT

VS

S070C-□□C-32  
Plug lead type

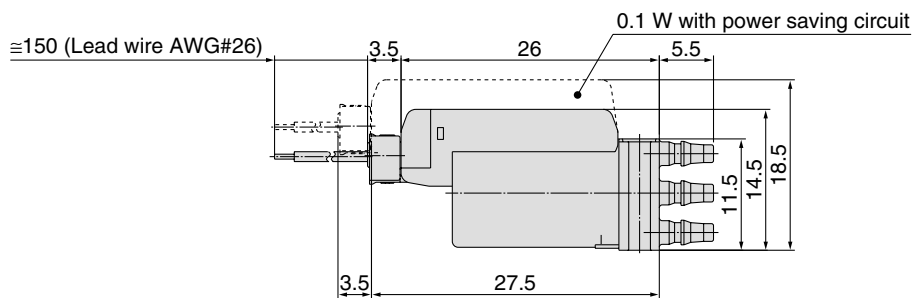

# 3 Port Solenoid Valve

## Series S070/Base Mounted Manifold

### Separable Base Type

#### How to Order Manifold

Base mounted manifold separable base

**SS07 3 A01 - 08 C**

Ports  
3 3 port

Port size

Symbol	SUP/EXH port (Applicable tubing)	OUT port	
		Applicable tubing	
A01	Barb fittings (ø6/ø4)	Barb fittings	ø3.18/ø2
A02			ø4/ø2.5
A03			ø2/ø1.2

Note) The outside and inside diameters of the "applicable tubing" are indicated for the barb fitting.

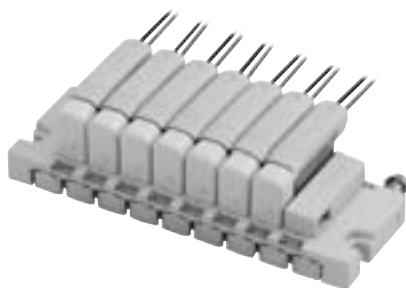

Stations

02	2 stations
03	3 stations
⋮	⋮
20	20 stations

Note) Maximum of 20 stations

Electrical entry

C	Grommet/Plug lead
---	-------------------

#### How to Order Manifold Assembly

Enter the part numbers of the valves and options to be mounted below the manifold base part number.

<Example>  
**SS073A01-04C** — 1 set — Manifold Base no.  
**\*S070A-5BG** — 3 sets — Valve no.  
**\*SS070A-10A** — 1 set — Blanking plate assembly no.

→ Prefix the symbol "\*" to the solenoid valve part number.

Write sequentially from the 1st station on the D side.

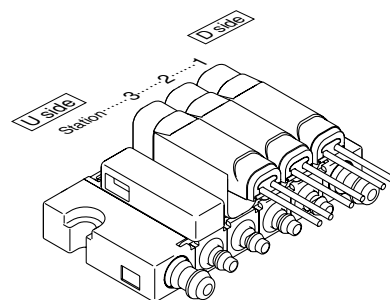

#### How to Order Valves

**S070 A - 5 B G**

Body type

Symbol	Body type
A	Base mounted with clips

Electrical entry

G	Grommet
C	Plug lead with light/surge voltage suppressor
CO	Plug lead without connector and with light/surge voltage suppressor

Coil voltage

5	24 VDC
6	12 VDC
V	6 VDC
S	5 VDC
R	3 VDC

Power consumption – Pressure specification – Flow rate

Symbol	Power consumption (W)	Maximum operating pressure (MPa)	Cv factor
A	0.35	0.1	0.016
B		0.3	0.011
C	0.5	0.3	0.016
D		0.5	0.011
E Note)	0.1 (With power saving circuit)	0.1	0.011
F Note)		0.3	0.006

Note) An option only applicable to 24 VDC plug lead type.



**Dimensions**

**Base mounted manifold/Separable base**

SS073A<sup>01</sup>/<sub>02</sub> Stations **C**

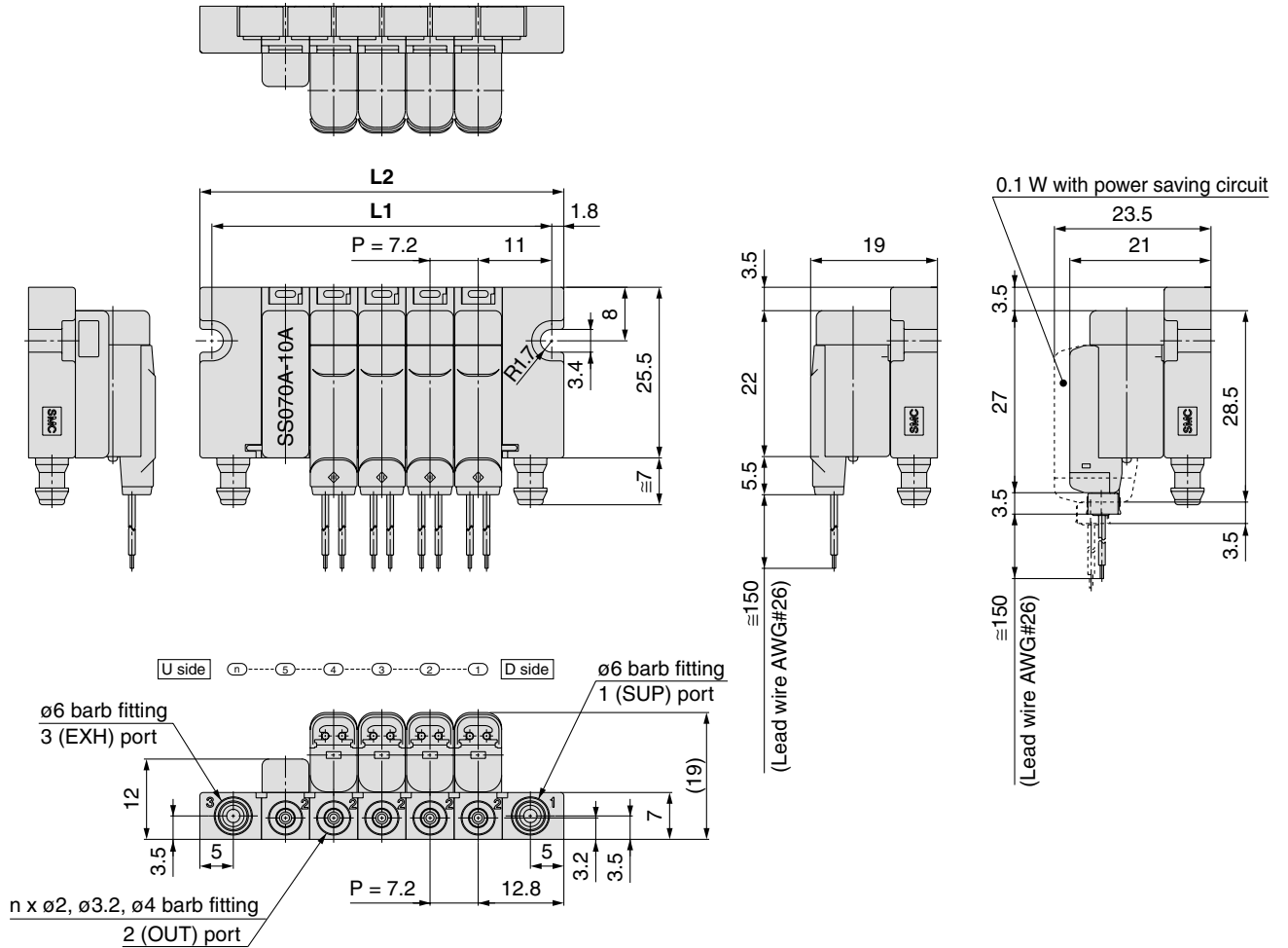

- VV061
- V100
- S070**
- VQD
- VKF
- VK
- VT
- VS

**Dimensions**

Formulas:  $L1 = n \times 7.2 + 14.8$ ,  $L2 = n \times 7.2 + 18.4$ , n: Stations (maximum 20 stations)

L	n	2	3	4	5	6	7	8	9	10	11	12	13	14	15	16	17	18	19	20
L1		29.2	36.4	43.6	50.8	58	65.2	72.4	79.6	86.8	94	101.2	108.4	115.6	122.8	130	137.2	144.4	151.6	158.8
L2		32.8	40	47.2	54.4	61.6	68.8	76	83.2	90.4	97.6	104.8	112	119.2	126.4	133.6	140.8	148	155.2	162.4

# 3 Port Solenoid Valve

## Series S070/Base Mounted Manifold

# Bar Base Specifications

### How to Order Manifold

Base mounted manifold bar base

**SS07 3 B01-08 C**

**Ports**  
3 3 port

**Port size**

Symbol	SUP/EXH port (Applicable tubing)		OUT port
			Applicable tubing
<b>B01</b>	M5 female screw	M3 female screw	—

**Stations**

<b>02</b>	2 stations
<b>03</b>	3 stations
⋮	⋮
<b>20</b>	20 stations

Note) Maximum of 20 stations

**Electrical entry**

<b>C</b>	Grommet/Plug lead
----------	-------------------



### How to Order Manifold Assembly

Enter the part numbers of the valves and options to be mounted below the manifold base part number.

<Example>

**SS073B01-04C** — 1 set — Manifold Base no.

**\*S070B-5BG** — 3 sets — Valve no.

**\*SS070B-10A** — 1 set — Blanking plate assembly no.

→ Prefix the symbol "\*" to the solenoid valve part number.

Write sequentially from the 1st station on the D side.

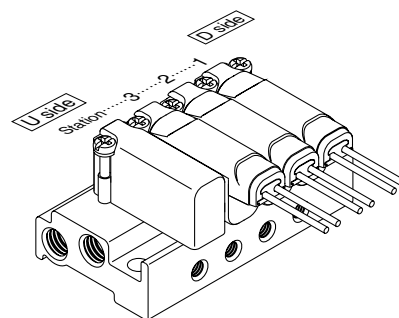

### How to Order Valves

**S070 B-5 B G**

**Body type**

Symbol	Body type
<b>B</b>	Base mounted with screws

**Electrical entry**

<b>G</b>	Grommet
<b>C</b>	Plug lead with light/surge voltage suppressor
<b>CO</b>	Plug lead without connector and with light/surge voltage suppressor

**Coil voltage**

<b>5</b>	24 VDC
<b>6</b>	12 VDC
<b>V</b>	6 VDC
<b>S</b>	5 VDC
<b>R</b>	3 VDC

**Power consumption – Pressure specification – Flow rate**

Symbol	Power consumption (W)	Maximum operating pressure (MPa)	Cv factor
<b>A</b>	0.35	0.1	0.016
<b>B</b>		0.3	0.011
<b>C</b>	0.5	0.3	0.016
<b>D</b>		0.5	0.011
<b>E</b> (Note)	0.1 (With power saving circuit)	0.1	0.011
<b>F</b> (Note)		0.3	0.006

Note) An option only applicable to 24 VDC plug lead type.

**Dimensions**

Base mounted manifold/Bar base

SS073B01- Stations C

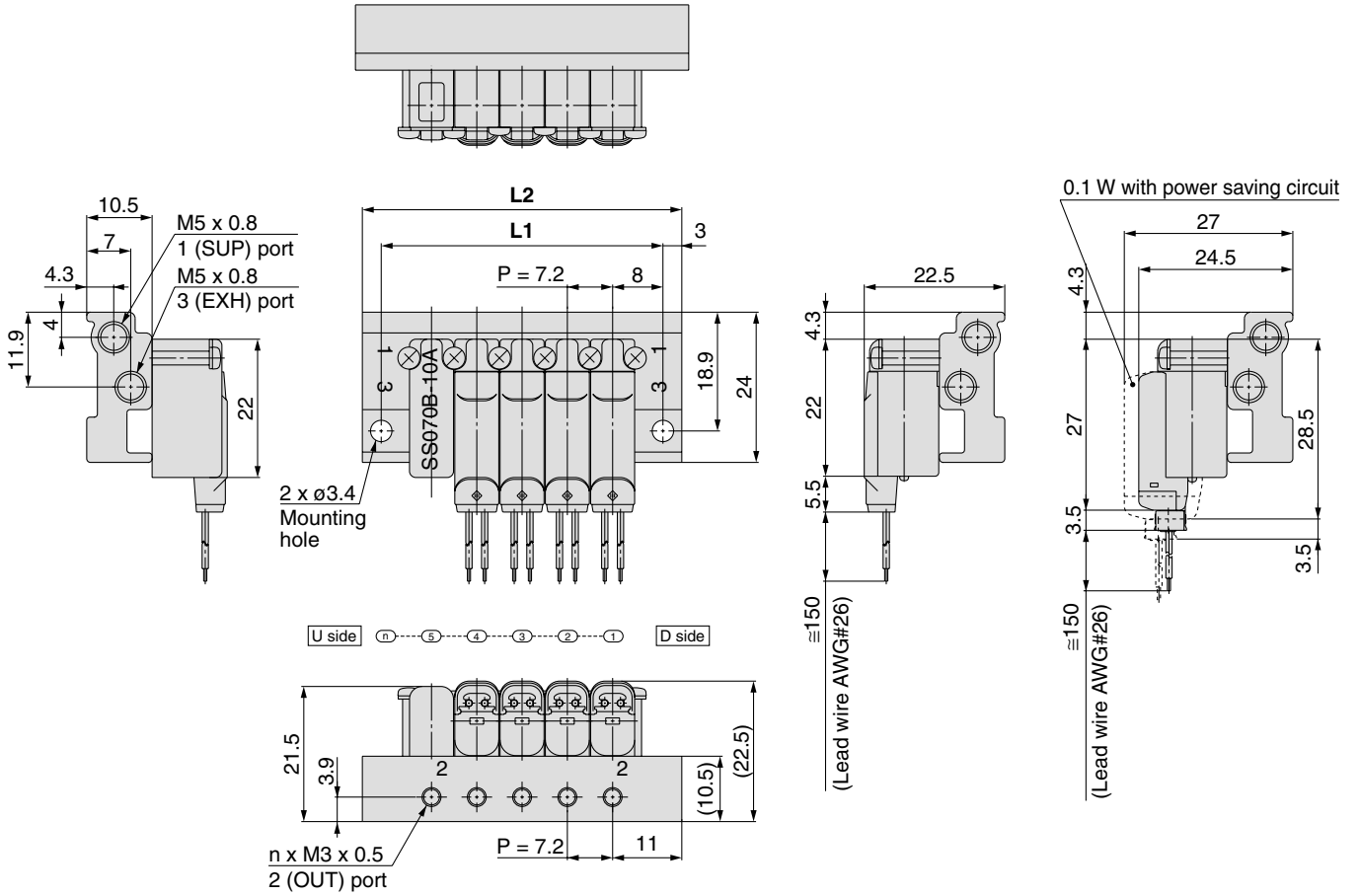

- VV061
- V100
- S070**
- VQD
- VKF
- VK
- VT
- VS

**Dimensions**

Formulas:  $L1 = n \times 7.2 + 8.8$ ,  $L2 = n \times 7.2 + 14.8$ , n: Stations (maximum 20 stations)

L \ n	2	3	4	5	6	7	8	9	10	11	12	13	14	15	16	17	18	19	20
<b>L1</b>	23.2	30.4	37.6	44.8	52	59.2	66.4	73.6	80.8	88	95.2	102.4	109.6	116.8	124	131.2	138.4	145.6	152.8
<b>L2</b>	29.2	36.4	43.6	50.8	58	65.2	72.4	79.6	86.8	94	101.2	108.4	115.6	122.8	130	137.2	144.4	151.6	158.8

# 3 Port Solenoid Valve

## Series S070/Base Mounted Manifold

# Stacking Type Specifications

### How to Order Manifold

Body ported manifold stacking type

**SS07 3 M01 - 08 C**

Ports  
3 3 port

Port size

Symbol	SUP/EXH port (Applicable tubing)	OUT port	
		Barb fittings	Applicable tubing
M01	Barb fittings ( $\phi 6/\phi 4$ )	Barb fittings	$\phi 3.18/\phi 2$
M02		Barb fittings	$\phi 4/\phi 2.5$

Note) The outside and inside diameters of the "applicable tubing" are indicated for the barb fitting.

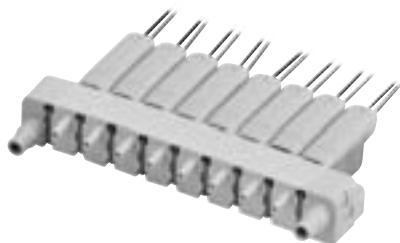

Stations

02	2 stations
03	3 stations
⋮	⋮
20	20 stations

Note) Maximum of 20 stations

Electrical entry

C	Grommet/Plug lead
---	-------------------

### How to Order Manifold Assembly

Enter the part numbers of the valves and options to be mounted below the manifold base part number.

<Example>  
**SS073M01-04C** — 1 set ——— Manifold Base no.  
**\*S070M-5BG-32** — 4 sets ——— Valve no.

Prefix the symbol "\*" to the solenoid valve part number.

Write sequentially from the 1st station on the D side.

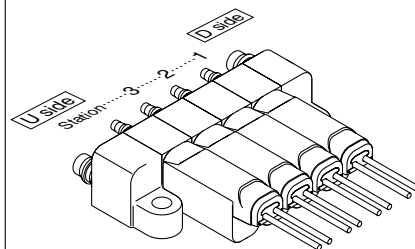

### How to Order Valves

**S070 M - 5 B G - 32**

Body type

Symbol	Body type
M	Body ported stacking manifold type

Coil voltage

5	24 VDC
6	12 VDC
V	6 VDC
S	5 VDC
R	3 VDC

Port size

Symbol	Connection	Applicable tubing
32	Barb fitting	$\phi 3.18/\phi 2$
40		$\phi 4/\phi 2.5$

Electrical entry

G	Grommet
C	Plug lead with light/surge voltage suppressor
CO	Plug lead without connector and with light/surge voltage suppressor

Power consumption – Pressure specification – Flow rate

Symbol	Power consumption (W)	Maximum operating pressure (MPa)	Cv factor
A	0.35	0.1	0.016
B		0.3	0.011
C		0.3	0.016
D	0.5	0.5	0.011
E (Note)	0.1 (With power saving circuit)	0.1	0.011
F (Note)		0.3	0.006

Note) An option only applicable to 24 VDC plug lead type.

**Dimensions**

**Body ported stacking type manifold**

SS073M<sup>01</sup><sub>02</sub>- Stations **C**

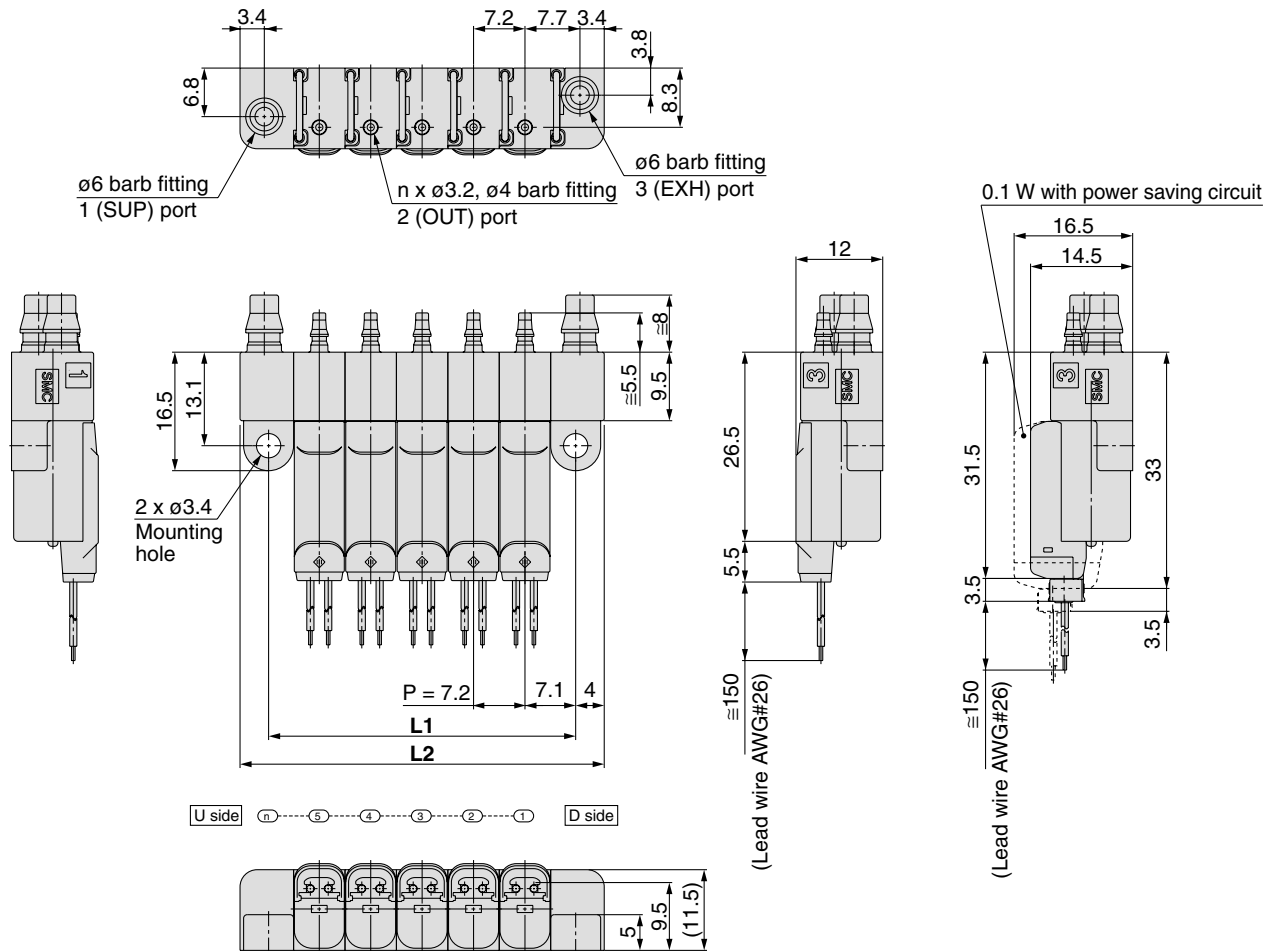

- VV061
- V100
- S070**
- VQD
- VKF
- VK
- VT
- VS

**Dimensions**

Formulas:  $L1 = n \times 7.2 + 7$ ,  $L2 = n \times 7.2 + 15$ , n: Stations (maximum 20 stations)

L \ n	2	3	4	5	6	7	8	9	10	11	12	13	14	15	16	17	18	19	20
L1	21.4	28.6	35.8	43	50.2	57.4	64.6	71.8	79	86.2	93.4	100.6	107.8	115	122.2	129.4	136.6	143.8	151
L2	29.4	36.6	43.8	51	58.2	65.4	72.6	79.8	87	94.2	101.4	108.6	115.8	123	130.2	137.4	144.6	151.8	159



## 1 Grommet Type: Special Lead Wire Length X26

S070 **B** - [ ] - [ ] **G** - [ ] - X26 - [ ]

- Coil voltage
- Body type
- Power consumption – Pressure specifications – Flow rate
- Grommet type
- Body ported: Port size  
No symbol is used for the base mounted type.
- Lead wire length (L)

Symbol	Length (L)
3	300 mm
6	600 mm
10	1000 mm

Symbol	Body type
A	Base mounted/Clipped
B	Base mounted/Screwed
C	Body ported/Single unit
M	Body ported/Stacking manifold type

## 2 Universal Specifications X50

S070 **B** - [ ] - [ ] **G** - [ ] - X50

- Body type
- Coil voltage
- Electrical entry
- Body ported: Port size  
No symbol is used for the base mounted type.
- Power consumption – Pressure specifications – Flow rate

Symbol	Power consumption	Operating pressure range	Flow characteristics		
			C (dm <sup>3</sup> /(s·bar))	b	CV
A	0.35 WDC	0 to 0.1 MPa	0.042	0.27	0.011
B		0 to 0.3 MPa	0.021	0.27	0.006
C	0.5 WDC	0 to 0.3 MPa	0.042	0.27	0.011
D		0 to 0.5 MPa	0.021	0.27	0.006

JIS Symbol

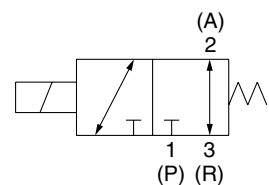

## 3 Normally Open Specifications X62

S070 **B** - [ ] - [ ] **G** - [ ] - X62

- Body type
- Coil voltage
- Electrical entry
- Body ported: Port size  
No symbol is used for the base mounted type.
- Power consumption – Pressure specifications – Flow rate

Symbol	Power consumption	Max. operating pressure (3 port pressure)	Flow characteristics		
			C (dm <sup>3</sup> /(s·bar))	b	CV
A	0.35 WDC	0 to 0.1 MPa	0.042	0.27	0.011
B		0 to 0.3 MPa	0.021	0.27	0.006
C	0.5 WDC	0 to 0.3 MPa	0.042	0.27	0.011
D		0 to 0.5 MPa	0.021	0.27	0.006

JIS Symbol

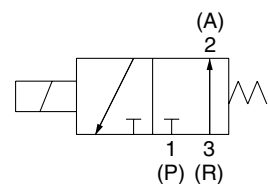

Note) When used in the vacuum release, use with 1-port vacuum, and 3-port vacuum release pressure.

## Manifold Options

### Blanking plate assembly (for SS073A)

#### SS070A-10A (for separable base)

This assembly is mounted on a manifold block where the valve is removed for maintenance or a replacement valve is going to be mounted.

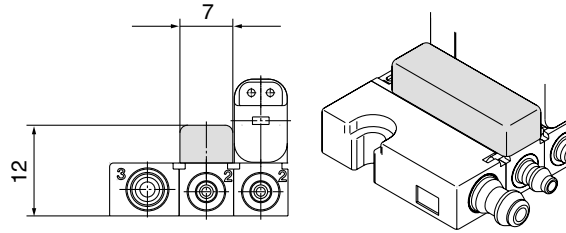

### Blanking plate assembly (for SS073B)

#### SS070B-10A (for bar base)

This assembly is mounted on a manifold block where the valve is removed for maintenance or a replacement valve is going to be mounted.

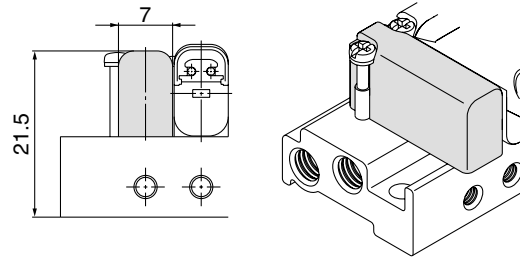

### Intermediate block assembly (for SS073A)

#### SS070A-B (for separable base)

This assembly is used to secure the manifold when a large number of stations are manifolded. (Accommodated as one station.)  
\* In the manifold specification sheet, specify the position where the block assembly is mounted.

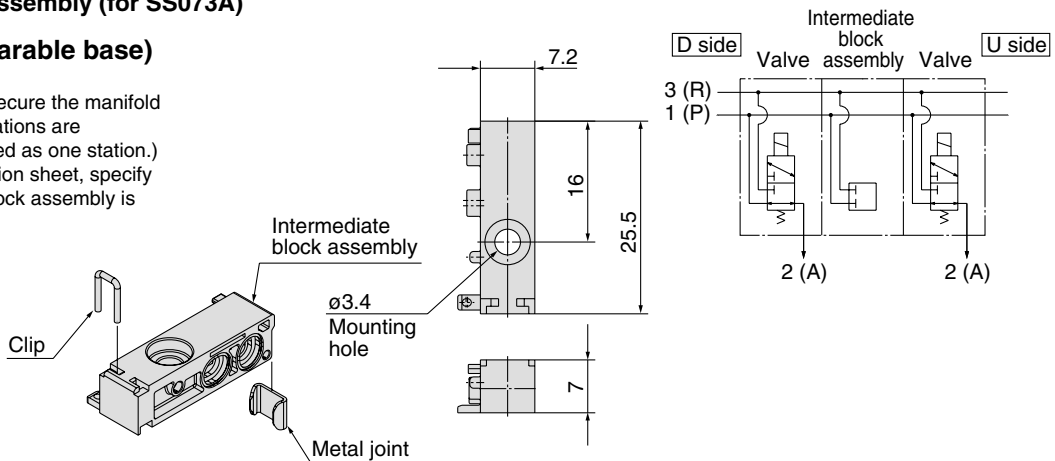

### Intermediate block assembly (for SS073M)

#### SS070M-B (for stacking type)

This assembly is used to secure the manifold when 20 or more stations are manifolded. (Accommodated as one station.)  
\* In the manifold specification sheet, specify the position where the block assembly is mounted.

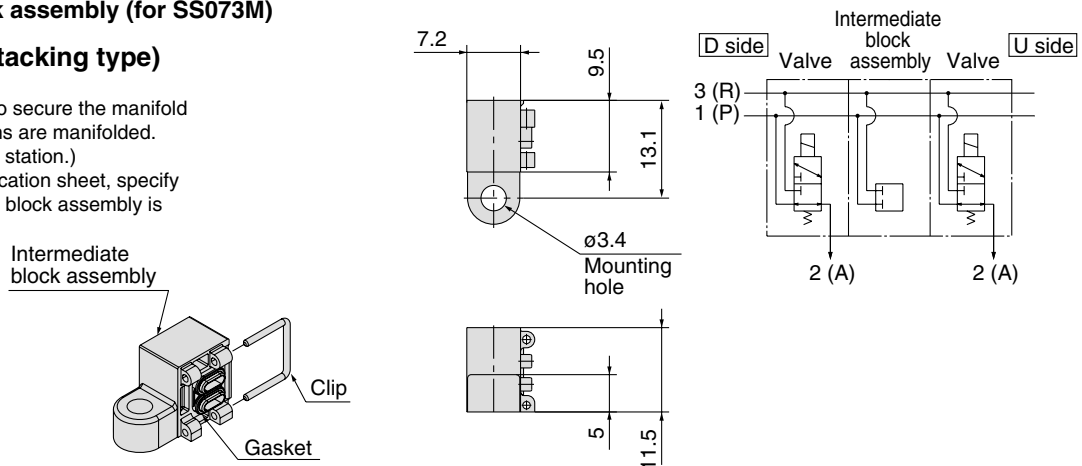

VV061

V100

S070

VQD

VKF

VK

VT

VS

Series **S070**

# Exploded View of Stacking Type

Body Ported Type/SS073M01-□C Exploded View of Stacking Type

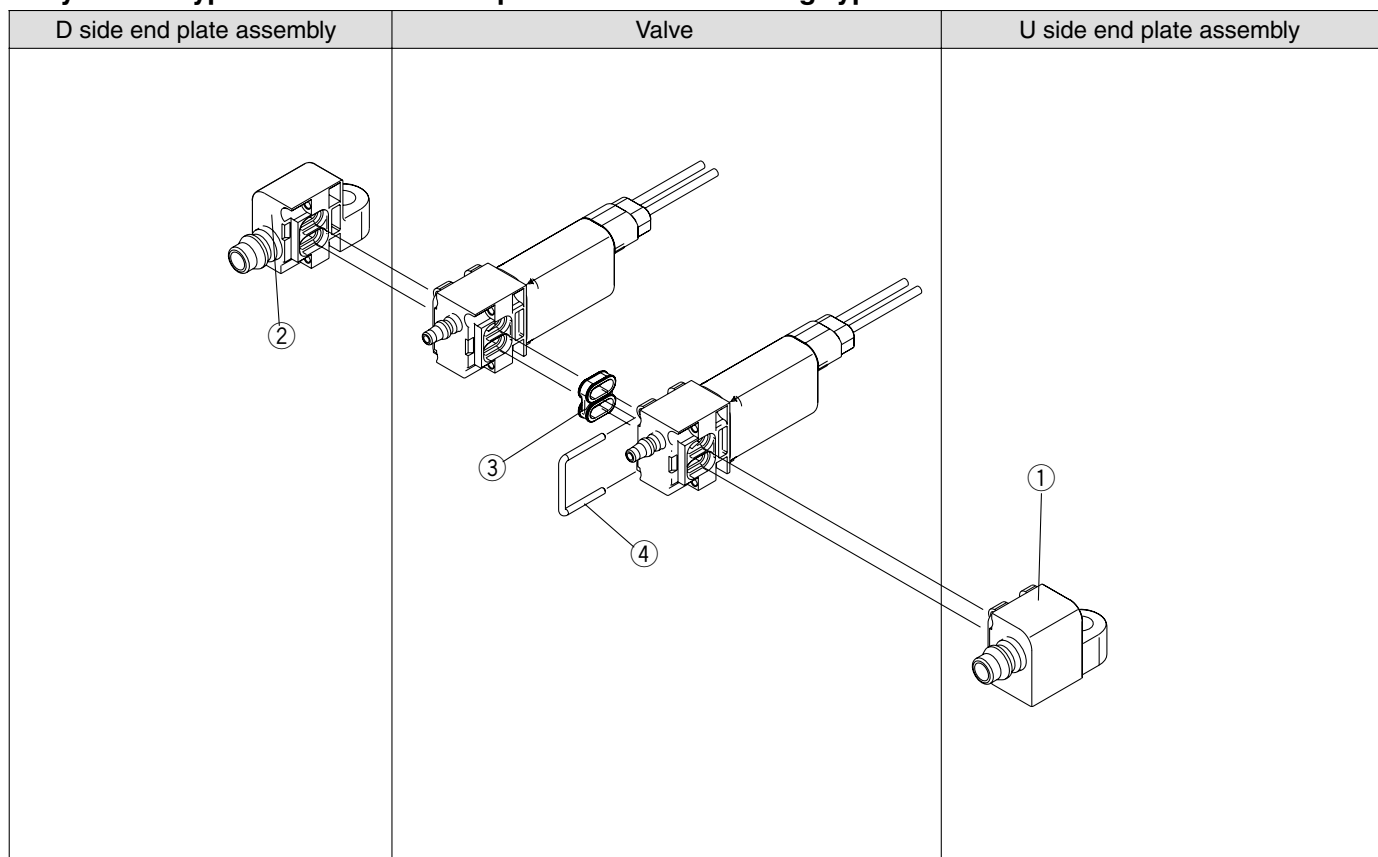

**< U End Plate Assembly >**

① U end plate assembly no.

**SS070M01-2A**

**< D End Plate Assembly >**

② D end plate assembly no.

**SS070M01-3A**

**Replacement Parts**

No.	Part no.	Description	Material	Number
③	S070M-80A-1	Gasket	FKM	10
④	SS070M-80A-2	Clip	Stainless steel	10



Series **S070**

# Exploded View of Separable Base

Base mounted/SS073A□-□C Exploded View of Separable Base

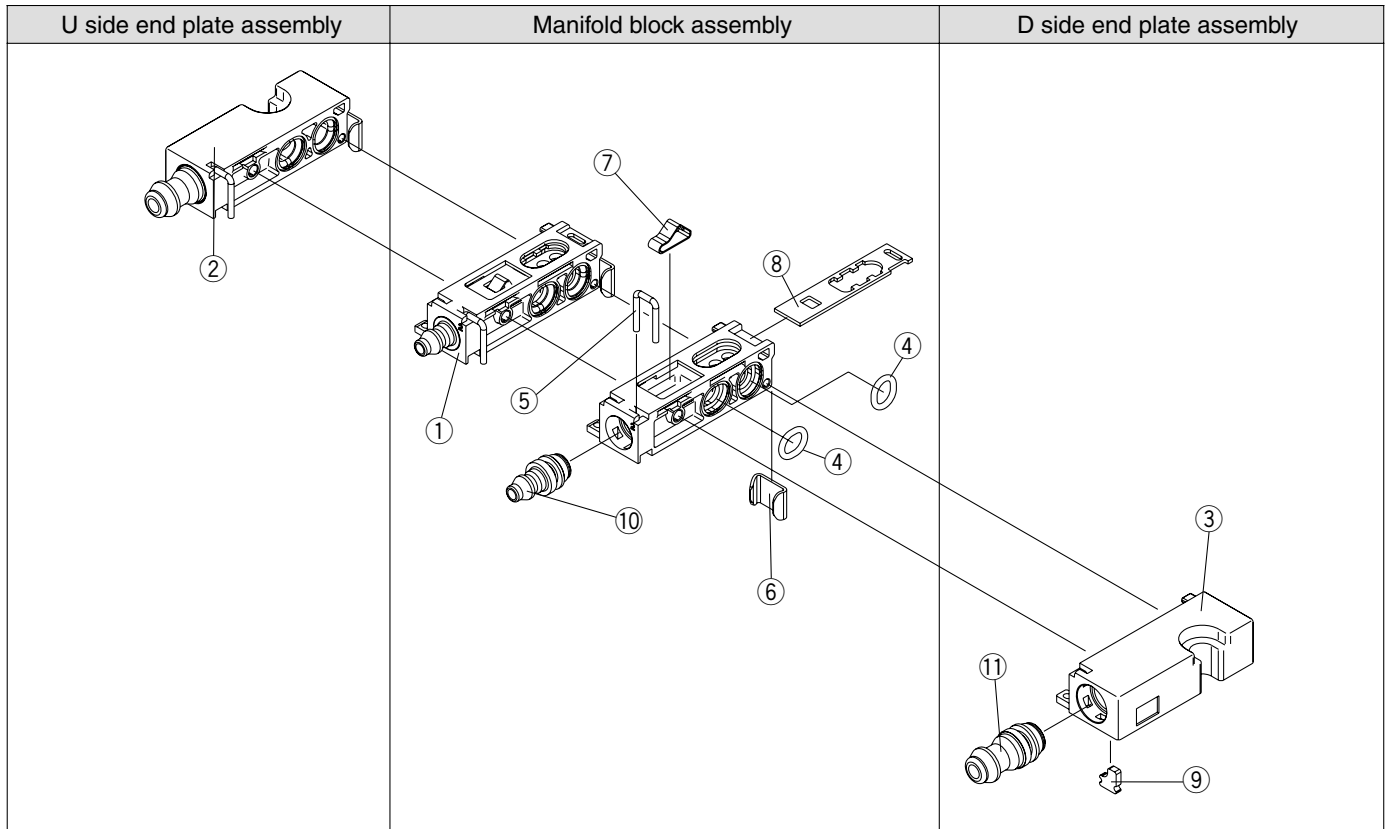

VV061  
V100  
**S070**  
VQD  
VKF  
VK  
VT  
VS

< Manifold Block Assembly >

① Manifold block assembly no.

**SS070A 01 -1A**

● Port size

01	With $\phi 3.18/\phi 2$ barb fitting
02	With $\phi 4/\phi 2.5$ barb fitting

< U Side End Plate Assembly >

② U side end plate assembly no.

**SS070A01-2A**

< D Side End Plate Assembly >

③ D side end plate assembly no.

**SS070A01-3A**

< Replacement Parts for Manifold Block >

Replacement Parts

No.	Part no.	Description	Material	Number
④	SS070A-80A-1	O-ring	FKM	10
⑤	SS070A-80A-2	Clip	Stainless steel	10
⑥	SS070A-80A-3	Metal joint	Stainless steel	10
⑦	SS070A-80A-4	Leaf spring	Stainless steel	10
⑧	SS070A-80A-5	Mounting bracket	Stainless steel	10

< Replacement Parts for U/D End Plate >

Replacement Parts

No.	Part no.	Description	Material	Number
⑨	SS070A-80A-6	Stopper plate	Stainless steel	10

< Barb Fitting Assembly >

⑩ Barb fitting assembly (for cylinder port)

**SS070-50A-32**

● Port size

20	Applicable tube $\phi 2/\phi 1.2$
32	Applicable tube $\phi 3.18/\phi 2$
40	Applicable tube $\phi 4/\phi 2.5$

🔍 Note) Order is accepted in 10 units.

⑪ Barb fitting assembly (for 1(P), 3(R) ports)

**SS070-51A-60**

● Applicable tubing  $\phi 6/\phi 4$

🔍 Note) Order is accepted in 10 units.



# Series S070

## Specific Product Precautions 1

Be sure to read before handling.

Refer to front matters 58 and 59 for Safety Instructions and pages 3 to 7 for 3/4/5 Port Solenoid Valve Precautions.

### ⚠ Caution

#### Valve Mounting/Removal

##### 1) Base mounted with screws

With the base mounted type fixed with screws, confirm the installation of the gasket mounted on the body interface and fasten the dedicated mounting screws (AXT632-106-1) at an appropriate torque (0.10 to 0.14 Nm). (Fasten equally so that the valve will not tilt.)



##### 2) Base mounted with clips

① Hook a flat head watchmakers' screwdriver into the hole of the metal bracket and pull it approximately 1 mm in the direction indicated by the arrow. ② Insert the solenoid valve from above. After confirming that the bottom surface of the solenoid valve contacts the top surface of the manifold, detach the flat head screwdriver from the mounting bracket while holding the solenoid valve body. (Before mounting, confirm the installation of the interface gasket on the solenoid valve body.)

The built-in leaf spring returns the mounting bracket to its original position.

(Then confirm that the end of the mounting bracket is aligned with the side of the manifold block. Refer to the figure below.)

Similarly, to remove the valve, pull the mounting bracket and pull up the solenoid valve vertically. Use caution so that no excessive force is applied to the lead wire in mounting and removal.

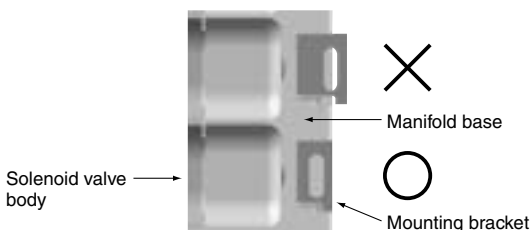
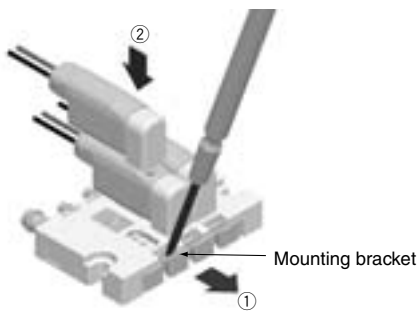

### ⚠ Caution

#### Screwing in M5/M3 Thread

After tightening by hand, tighten an additional 1/4 rotation for M3 and 1/6 rotation for M5. Overtightening may cause bending of the thread or air leakage due to deformation of the gasket. Insufficient screwing may cause loosening of the thread or air leakage.

#### Applicable Tubing Size

##### Stacking manifold

Port	Applicable tubing	Recommended tubing
1 (SUP), 3 (EXH)	ø6/ø4	TS0604/TU0604
2 (OUT)	ø4/ø2.5	TS0425/TU0425
	ø3.18/ø2	TIUB01

Note) In case of a body ported single unit valve, the applicable tubing size is ø3.18/ø2 for all 1 (SUP), 2 (OUT), and 3 (EXH) ports.

If fittings of a brand other than SMC are used, follow the specifications of the fittings to be mounted.

#### Tubing Installation (With barb fitting)

- Using tubing cutters TK-1, 2, or 3, cut the tubing perpendicularly to the tubing axis while allowing for sufficient margin to the required length.
- Insert the tubing and push it all the way to the barb end. If the tubing is not installed securely to the end, problems such as leakage or disconnection of the tubing can occur.
- When the tubing is inserted into the barb fitting, push it in the direction of the tubing axis to prevent excessive lateral loads being applied to the barb fitting.

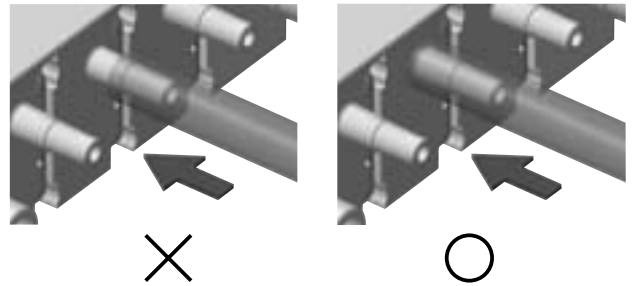

- To remove the tubing from the barb fitting, use caution so that no excessive lateral load will be applied to the barb fitting. When using a cutter to remove the tubing, sufficient care should be taken so as not to make any flaws on the barb fitting.
- After tubing installation, avoid excessive loads, such as tensile, compressive, or bending strength, being applied to the tubing.



# Series S070

## Specific Product Precautions 2

Be sure to read before handling.

Refer to front matters 58 and 59 for Safety Instructions and pages 3 to 7 for 3/4/5 Port Solenoid Valve Precautions.

### ⚠ Caution Mounting

#### 1) Solenoid valve fixing procedure (body ported single unit)

When mounting a body ported type single unit valve, tighten the dedicated mounting screw (AXT632-106A-2) at an appropriate torque (0.05 to 0.07 N·m) to firmly secure the valve body. (Tighten equally so that the valve will not tilt.) If the coil is fixed, the coil joint may break due to application of an excessive load to the tubing body, for example, when the tubing is inserted. With a base mounted type solenoid valve also, use caution to avoid excessive loads on the coil and lead wire.

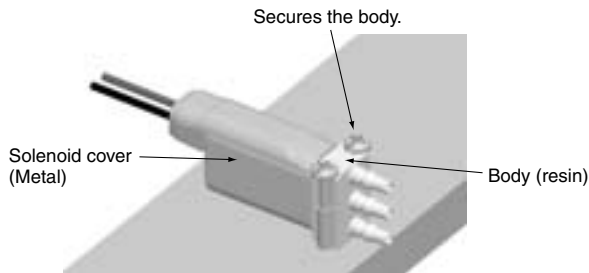

### ⚠ Caution Adding and Removing Manifold Stations

#### 1) Base mounted stacking type

- ① Remove the clip and metal joint from the position where the new station is to be mounted by pulling them in the directions indicated by the arrows.
- ② Place the additional manifold block assembly and mount the metal joint and clip by reversing the assembly order. Securely insert the clip and the metal joint so that they will not protrude from the top and bottom surfaces respectively.

The clip is commonly used to secure the manifold block and fittings.

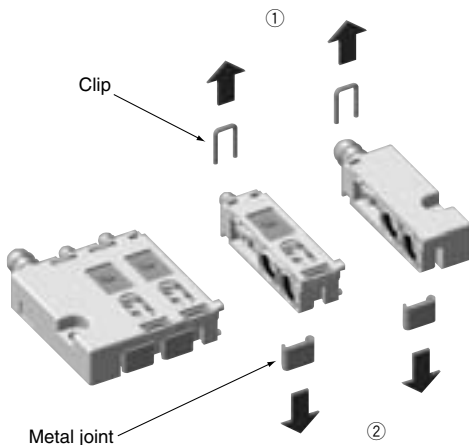

To remove the station, follow the same procedure for assembly and disassembly.

#### 2) Body ported manifold type

- ① Remove the clip on the position where the station is to be added by pulling it in the direction indicated by the arrow. (Insert a flat head screwdriver in the recess indicated in the figure to remove the clip.)
- ② Place the additional solenoid valve into the separation and insert the clip. Insert the clip until it fits in the groove on the body side.

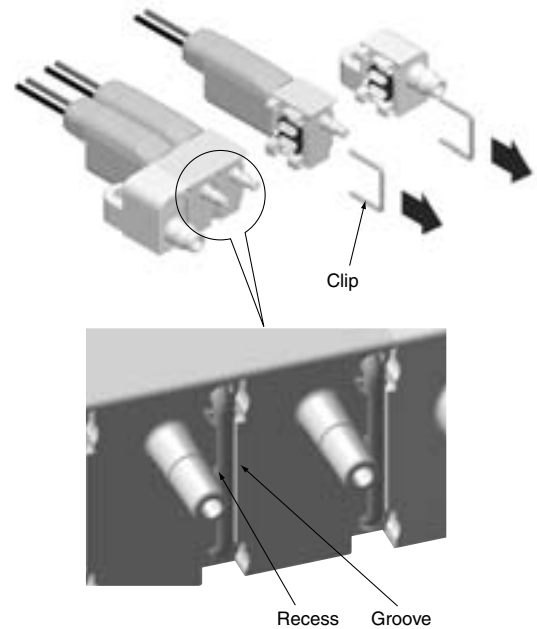

VV061
V100
<b>S070</b>
VQD
VKF
VK
VT
VS

### ⚠ Caution Vacuum Application

An N.C. type valve pressurized at 1 (SUP) port can be used within the maximum operating pressure differential specified for the product. If the valve is to be used in the following applications, however, care should be taken about the piping ports, maximum operating pressure differential and allowable leakage.

#### 1) Vacuum release application

Use 3 (R) port for vacuum pressure and 1 (P) port for vacuum release pressure. The pressure differential between 3 (R) and 1 (P) is the maximum operating pressure differential for each type.

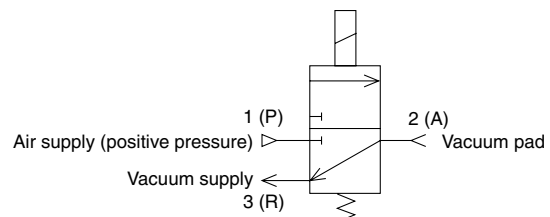

#### 2) Vacuum retention

Please consult SMC if the allowable leakage is limited when the valve is used for vacuum retention of a vessel, even within the low vacuum range ( $1.33 \times 10^2$  Pa or above).



# Series S070

## Specific Product Precautions 3

Be sure to read before handling.

Refer to front matters 58 and 59 for Safety Instructions and pages 3 to 7 for 3/4/5 Port Solenoid Valve Precautions.

### ⚠ Caution Wiring

#### 1) Internal wiring

- Grommet  
(This solenoid valve has no polarity.)

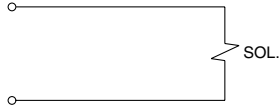

- With light/surge voltage suppressor  
(This solenoid valve has no polarity.)

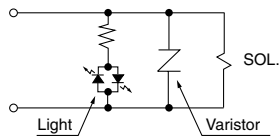

- With 0.1 W power saving circuit

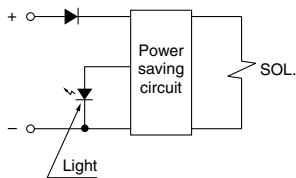

#### 2) Electrical circuit

- (1) Adopt an electrical circuit with no chattering generated at the contact.
- (2) Keep the voltage within the  $\pm 10\%$  range of the rated voltage.  
Care should be taken about the voltage drop when the rated voltage is 6 VDC or less or when the response speed is important.
- (3) When using a C-R element (surge voltage suppressor) for protection of the switching element, please keep in mind that leakage voltage will increase due to leakage current flowing through the C-R element.

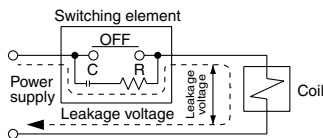

Keep the residual leakage voltage with 2% of the rated voltage.

- (4) Be sure to confirm the applied voltage. If a wrong voltage is applied, it can lead to malfunction or coil burning.
- (5) In wiring, use caution to avoid application of excessive force to the lead wire. It can cause malfunction or break the coil.

### ⚠ Caution

#### Power Saving Circuit of 0.1 W DC (At holding)

- 1) The power consumption is 0.35 W DC at inrush (100 ms) and 0.1 W DC at holding.